

FOOT VALVE – MODEL: FIG030

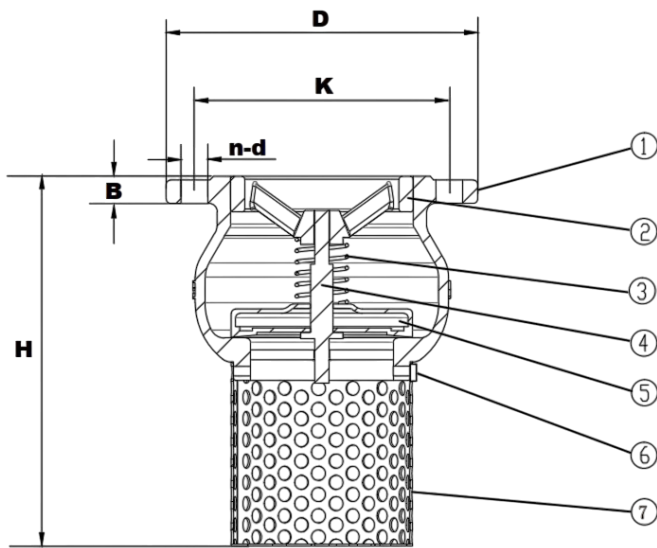

PRODUCTS STANDARDS

Design	BS / DIN
Flange	EN-1092-2, BS4504
Test	EN 12266-1
Working Pressure	PN10/PN16/PN25
Max Temp.	80°C



NO.	MAIN PART	MATERIAL
1	Body	DUCTILE IRON
2	Seat	DUCTILE IRON
3	Spring	SS 304
4	Stem	SS 420
5	Disc	DUCTILE IRON
6	Bolt	SS304
7	Screen	SS304

DN	D	K	B	H	PN10	PN16
					n- Φd	
50	165	125	19	190	4- Φ19	4- Φ19
65	185	145	19	210	4- Φ19	4- Φ19
80	200	160	19	240	8- Φ19	8- Φ19
100	220	180	19	250	8- Φ19	8- Φ19
125	250	210	19	310	8- Φ19	8- Φ19
150	285	240	19	370	8- Φ23	8- Φ23
200	340	295	20	450	8- Φ23	12- Φ23
250	405	355	22	470	12- Φ19	12- Φ28
300	460	410	25	500	12- Φ19	12- Φ28
350	505	460	25	650	16- Φ19	16- Φ28
400	565	515	25	720	16- Φ19	16- Φ31

Designs and specifications shown are subject to change without notice due to our continuing program of product development.