

OS&Y GATE VALVE– MODEL: FIG21

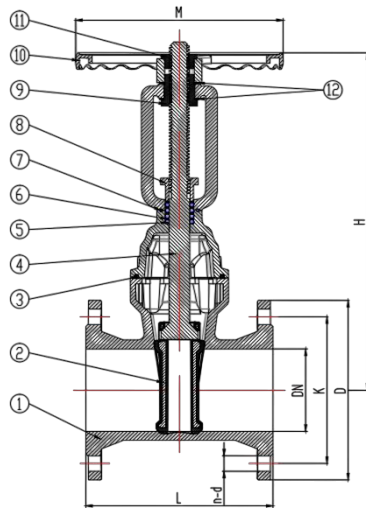

PRODUCTS STANDARDS

Design	EN 1171
Flange	EN 1092-2, BS 4504
Face to face	EN558-1 / ISO 5752
Test	EN 12266-1
Working Pressure	PN10/PN16/PN25
Max. Temperature	80°C

NO.	MAIN PART	MATERIAL
1	Body	DUCTILE IRON
2	Disc	DUCTILE IRON + EPDM
3	Bonnet gasket	NBR
4	Stem	SS420
5	O-ring	NBR
6	Sealing Washer	POLYOXYMETHYLÈNE
7	O-ring	NBR
8	Gland	DUCTILE IRON
9	Stem nut	Brass
10	Handwheel	DUCTILE IRON
11	Upper Stem nut	Brass
12	Cap	Brass

DN	OUTLINE (mm)			END FLANGE DIMENSIONS (mm)		
	BS5163	M	H	BS4504 / EN1092-2 PN10/16		
	L			D	K	n-d
40	165	200	290	150	110	4-Ø19
50	178	200	290	165	125	4-Ø19
65	190	200	350	185	145	4-Ø19
80	203	200	375	200	160	8-Ø19
100	229	254	450	220	180	8-Ø19
125	254	315	510	250	210	8-Ø19
150	267	315	585	285	240	8-Ø23
200	292	406	735	340	295	8-Ø23/12-Ø23
250	330	406	875	405	350/355	12-Ø23/12-Ø28
300	356	500	1015	460	400/410	12-Ø23/12-Ø28
350	381	500	1210	520	460/470	16-Ø23/16-Ø28
400	406	650	1335	580	515/525	16-Ø28/16-Ø31
450	432	650	1515	640	565/585	20-Ø28/20-Ø34
500	457		1600	670/715	620/650	20-Ø28/20-Ø34

Designs and specifications shown are subject to change without notice due to our continuing program of product development.