

AIR RELEASE VALVE – MODEL: FIG09

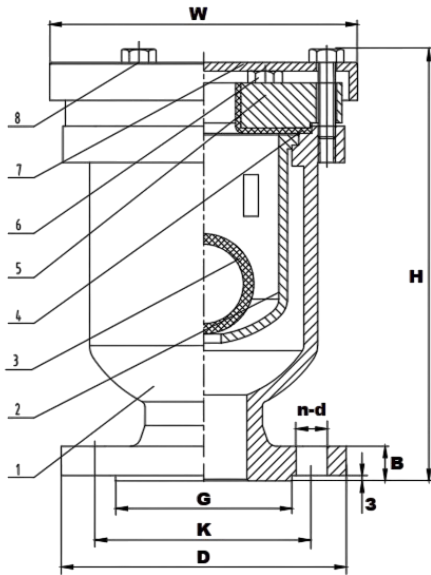

PRODUCTS STANDARDS

Design	BS / DIN /EN
Flange	BS4504 / EN 1092-2
Test	EN 12266-1
Working Pressure	PN10/PN16
Max Temp.	80°C

NO.	MAIN PART	MATERIAL
1	Body	DUCTILE IRON
2	Bucket	DUCTILE IRON
3	Ball Float	ABS/SS
4	Gasket	NBR
5	Inside Cover	DUCTILE IRON
6	Bolt	SS304 / C.S
7	Outside Cover	DUCTILE IRON
8	Bolt	SS304 / C.S

SIZE		W	H	Flange (mm) EN1092-2, PN10/16				
DN	inch			n-d	K	D	G	B
40	1.5"	166	224	4-Ø19	110	165	99	19
50	2"	178	236	4- Ø 19	125	165	99	19
65	2.5"	199	244	4- Ø 19	145	185	118	19
80	3"	202	248	8- Ø 19	160	200	132	19
100	4"	233	284	8- Ø 19	180	220	156	19
125	5"	282	324	8- Ø 19	210	285	211	19
150	6"	282	324	8- Ø 23	240	285	211	19

Designs and specifications shown are subject to change without notice due to our continuing program of product development.