

SWING CHECK VALVE – MODEL: FIG02

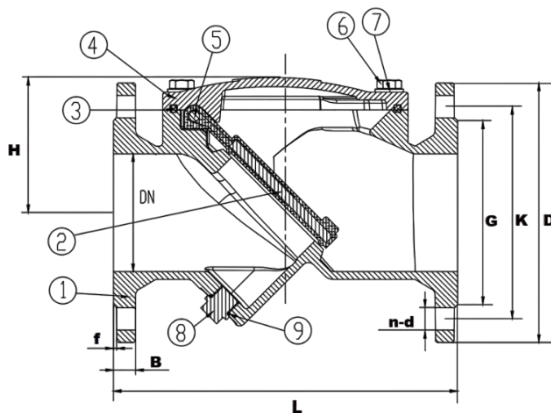

PRODUCTS STANDARDS

| | |
|------------------|----------------------|
| Design | BS5153 / DIN3202-F6 |
| Flange | BS4504 / EN 1092-2 |
| Face to face | ANSI B16.10/ BS 1868 |
| Tests | EN 12266-1 |
| Working Pressure | PN10/PN16/PN25 |
| Max Temperature | 80°C |

| NO. | MAIN PART | MATERIAL |
|-----|-----------|------------------|
| 1 | Body | DUCTILE IRON |
| 2 | Cover | WCB + EPDM / NBR |
| 3 | Gasket | NBR / EPDM |
| 4 | Cover | DUCTILE IRON |
| 5 | Shaft Pin | SS304 / SS316 |
| 6 | Bolt | SS304 / SS316 |
| 7 | Washer | SS304 / SS316 |
| 8 | Plug | SS304 / SS316 |
| 9 | O-Ring | NBR / EPDM |

| DN | OUTLINE mm | | | | | Flange Dimension (EN1092-2 / BS4504) | | | | | | | |
|-----|------------------|--------|------|---|-----|--------------------------------------|-----|-----|--------|------|-----|-----|--------|
| | Face to face (L) | | B | f | H | PN10 | | | | PN16 | | | |
| | BS5153 | DIN-F6 | | | | D | K | G | n-d | D | K | G | n-d |
| 50 | 203 | 200 | 19 | 3 | 95 | 165 | 125 | 98 | 4-ø19 | 165 | 125 | 99 | 4-ø19 |
| 65 | 216 | 240 | 19 | 3 | 100 | 185 | 145 | 118 | 4-ø19 | 185 | 145 | 118 | 4-ø19 |
| 80 | 241 | 260 | 19 | 3 | 105 | 200 | 160 | 132 | 8-ø19 | 200 | 160 | 132 | 8-ø19 |
| 100 | 292 | 300 | 19 | 3 | 115 | 220 | 180 | 156 | 8-ø19 | 220 | 180 | 156 | 8-ø19 |
| 125 | 330 | 350 | 19 | 3 | 145 | 250 | 210 | 184 | 8-ø19 | 250 | 210 | 184 | 8-ø19 |
| 150 | 356 | 400 | 19 | 3 | 155 | 285 | 240 | 211 | 8-ø23 | 285 | 240 | 211 | 8-ø23 |
| 200 | 495 | 500 | 20 | 3 | 250 | 340 | 295 | 266 | 8-ø23 | 340 | 295 | 266 | 8-ø23 |
| 250 | 622 | 600 | 22 | 3 | 300 | 405 | 350 | 319 | 12-ø23 | 405 | 355 | 319 | 12-ø28 |
| 300 | 698 | 700 | 24.5 | 4 | 330 | 460 | 400 | 370 | 12-ø23 | 460 | 410 | 370 | 12-ø28 |
| 350 | 787 | - | 26.5 | 4 | - | 520 | 460 | 429 | 16-ø23 | 520 | 470 | 429 | 16-ø28 |
| 400 | 914 | - | 28 | 4 | - | 580 | 515 | 480 | 16-ø28 | 580 | 525 | 480 | 16-ø31 |
| 450 | 965 | - | 30 | 4 | - | 640 | 565 | 530 | 20-ø28 | 640 | 585 | 548 | 20-ø31 |
| 500 | 1067 | - | 31.5 | 4 | - | 715 | 620 | 582 | 20-ø28 | 715 | 650 | 609 | 20-ø34 |
| 600 | 1219 | - | 36 | 5 | - | 840 | 725 | 682 | 20-ø31 | 840 | 770 | 720 | 20-ø37 |

Designs and specifications shown are subject to change without notice due to our continuing program of product development.