

WET ALARM CHECK VALVE – MODEL: FIG15

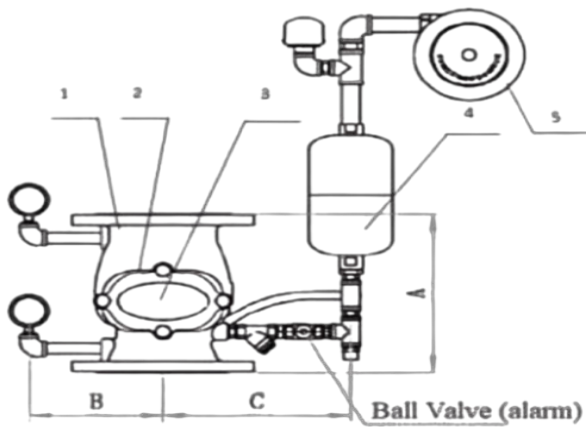

PRODUCTS STANDARDS

Design	EN / BS / DIN
Flange	EN 1092-2, BS 4504
Face to face	EN558-1
Tests	EN 12266-1
Working Pressure	PN10/PN16
Max. Temperature	80°C

NO.	MAIN PART	MATERIAL
1	Body	DUCTILE IRON
2	Diaphragm	SYNTHETIC RUBBER
3	Bonnet	DUCTILE IRON
4	Delayer	DUCTILE IRON
5	Water Motor Gong	DUCTILE IRON

DN	A	B	C	D	E
100	250	182	265	170	120
125	250	182	265	170	120
150	300	195	280	190	150
200	350	225	315	220	170

Designs and specifications shown are subject to change without notice due to our continuing program of product development.