

**PRESSURE RELIEF VALVE – MODEL: FIG11**  
**DN50 – DN350**

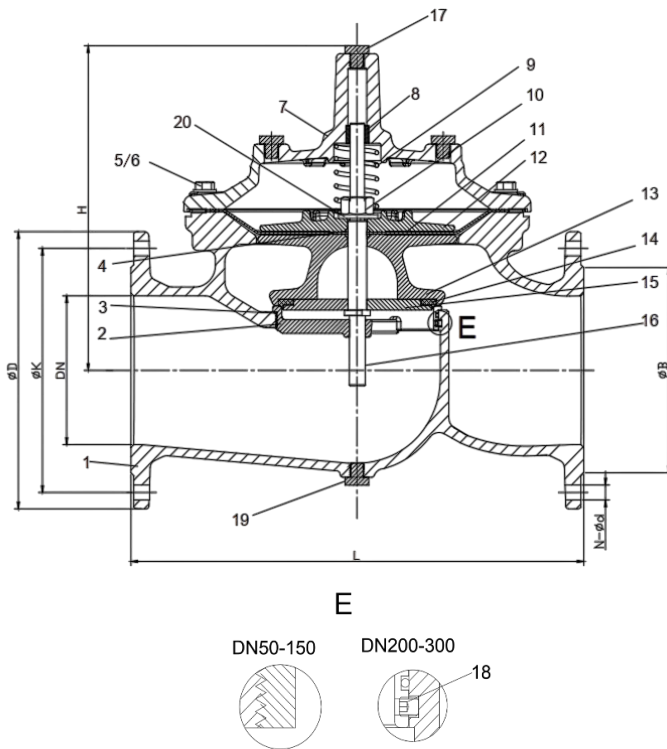

**PRODUCTS STANDARDS**

Design	EN 1074 , EN 1171 , EN558-1
Flange	EN1092-2, BS 4504
Face to face	GB/T1221, BS EN558-1
Tests	BS EN12266-1
Working Pressure	PN10/PN16/PN25
Max Temperature	80°C

NO.	MAIN PART	MATERIAL
1	Body	Ductlie Iron
2	Seat	Stainless Steel
3	O-ring	Rubber
4	O-ring	Rubber
5	Bolt	Stainless Steel
6	Washer	Stainless Steel
7	Bonnet	Ductlie Iron
8	Bush	Brass
9	Spring	Stainless Steel
10	Caulking Nut	Stainless Steel
11	Diaphragm	Nylon Reinforced Rubber
12	Fixing holder	Ductlie Iron
13	Disc Holder	Ductlie Iron
14	Seal	Rubber
15	Seat Retainer	Stainless Steel
16	Stem	Stainless Steel
17	Plug	Stainless Steel
18	Screw	Stainless Steel
19	Plug	Stainless Steel
20	Washer	Stainless Steel

DN	L	H	ØD			ØK			N-Ød			ØB		
			PN10	PN16	PN25	PN10	PN16	PN25	PN10	PN16	PN25	PN10	PN16	PN25
50	230	177	165	165	165	125	125	125	4-Ø19	4-Ø19	4-Ø19	Ø99	Ø99	Ø99
65	290	202	185	185	185	145	145	145	4-Ø19	4-Ø19	8-Ø19	Ø118	Ø118	Ø118
80	310	2196	200	200	200	160	160	160	8-Ø19	8-Ø19	8-Ø19	Ø132	Ø132	Ø132
100	350	243	220	220	235	180	180	190	8-Ø19	8-Ø19	8-Ø23	Ø156	Ø156	Ø156
125	400	243	250	250	270	210	210	220	8-Ø19	8-Ø19	8-Ø28	Ø156	Ø156	Ø156
150	480	333	285	285	300	240	240	250	8-Ø23	8-Ø23	8-Ø28	Ø211	Ø211	Ø211
200	600	428	340	340	360	295	295	310	8-Ø23	12-Ø23	12-Ø28	Ø266	Ø266	Ø274
250	730	478	405	405	425	350	355	370	12-Ø23	12-Ø28	12-Ø31	Ø319	Ø319	Ø330
300	850	538	460	460	85	400	410	430	12-Ø23	12-Ø28	16-Ø31	Ø370	Ø370	Ø389
350	980	550	520	520	555	460	470	490	16-Ø23	16-Ø28	16-Ø34	Ø429	Ø429	Ø448

Designs and specifications shown are subject to change without notice due to our continuing program of product development.